

Tile Mount Carrier

SPECIFICATION

The Enlighted Tile Mount Carrier is a flexible mounting solution for the SU-5E Micro sensor in acoustical ceiling tile installations. The Tile Mount Carrier provides adequate framing around the sensor in the tile securely supporting it with a large backup nut.



OVERVIEW

The Enlighted Tile Mount Carrier is a mounting solution for the SU-5E Micro sensor especially for use in acoustical ceiling tile installations. The nature of acoustical ceiling tiles, typically used in suspended ceiling applications, is that the tile material is ‘crumbly’ and cannot be depended on to retain the sensor firmly in a drilled hole in the tile, especially if the sensor is removed and re-inserted into the tile over the lifetime of the installation.

The Tile Mount Carrier provides a large backup nut that will allow it to securely support the sensor in the hole drilled in the acoustic tile. The front face of the mount blends with the Micro sensor for clean aesthetics. The Tile Mount Carrier may also be used in other ceiling or fixture materials with a wide range or material thickness (from 1/16" to 1.5"), so long as there is access to the rear side of the material so that the backup nut can be installed.

Tile Mount Carrier		
Diameter	0.83"	21.0 mm
Depth	1.9"	48.0 mm
Tile Mount Nut		
Diameter	1.12"	28.4 mm
Depth	1.18"	29.1 mm

FEATURES

- Designed for mounting in a 7/8" (22 mm) diameter hole.
- Push in design requires no special tools for sensor insertion into and removal from the carrier.
- Can be used in a wide range of materials and material thickness from 1/16" to 1.5" (1.5 mm ~ 38 mm) thick.
- Requires access to the rear side of the mounting surface.

DIMENSIONS

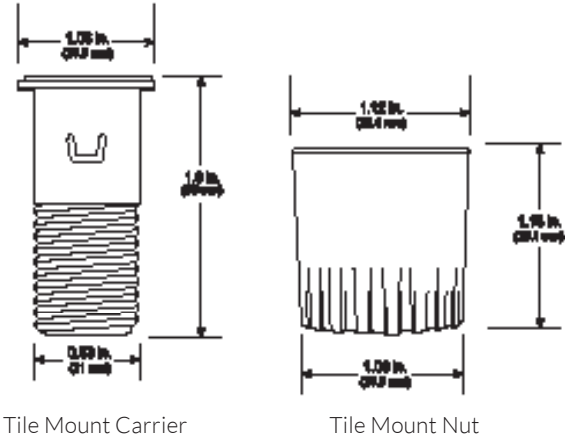

ENLIGHTED SPECIFICATION SUBMITTAL

Job Name:

Job Number:

Product Codes:

TMC-SU-5E

SU-5E-[IoT/CL/IL]

Tile Mount Carrier

INSTALLATION

1. Mark the location of the sensor on the face of the ceiling tile.
2. Remove the ceiling tile from the suspension grid.
3. Drill a 7/8" (22 mm) diameter hole in the ceiling tile where the sensor is to be mounted. Be careful to minimize drill breakthrough damage to the tile. Use a backup board behind the tile if necessary to minimize damage to the tile.
4. Insert the threaded end of the Tile Mount Carrier through the hole from the front side of the tile.
5. Thread the plain end of the Tile Mount Nut onto the threaded end of the Tile Mount Carrier from behind the tile to secure the carrier – do not overtighten. **Note:** The tile mount nut may be reversed for thicker materials.
6. Place the ceiling tile back in the suspension grid, leaving access to reach the sensor cable.
7. Insert the sensor cable through the opening of the Tile Mount Carrier.
8. Return the tile to its seated position in the ceiling grid.
9. Connect the SU-5E Micro sensor to the cable.
10. Push the SU-5E sensor into the Tile Mount Carrier until it is flush with the face of the Tile Mount Carrier.

For extremely thick material (between 3/4" and 1 1/2"), reverse the Tile Mount Nut so that the smaller diameter end is facing the material.

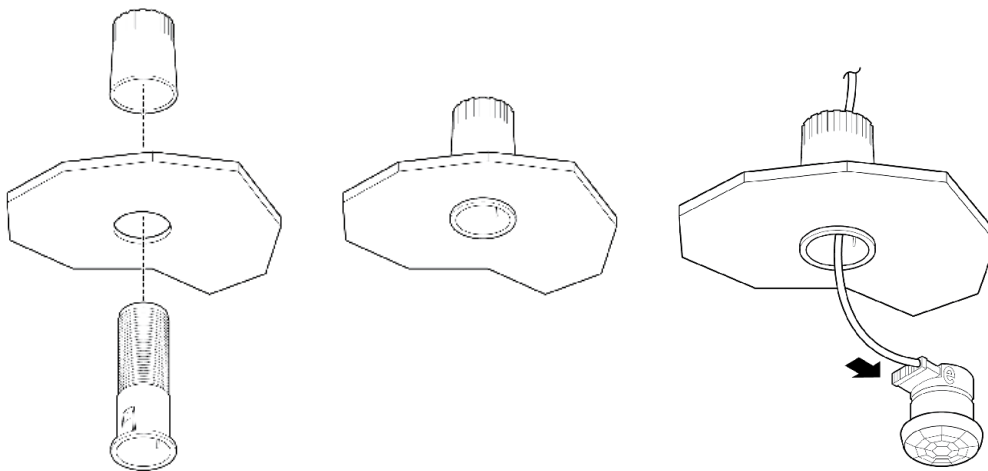

TECHNICAL SPECIFICATIONS

Material: Wonderloy® PC-540 PC+ABS Alloy

Weight: 10 grams

ORDERING INFORMATION

TMC-SU-5E Micro sensor Tile Mount Carrier

SU-5E-[IoT/CL/IL] Micro sensor